

LASER CUT & LASER GUIDE

by C L A I N D

**The nitrogen
generators
for laser cutting
and inert gas
generators
for beam guide
pressurization**





**SELF-GENERATION = FREEDOM AND
+ RESPECT FOR THE ENVIRONMENT**



The solutions for the self-production of nitrogen

Lasercutting technology needs ultrapure nitrogen to have a brilliant and stainless cut, to rapidly remove the molten metal from the cutting zone without reacting with it and additionally requiring a mixture of inert gas to protect laser machine optics, reducing the risks of the intrusion of impurities, significantly extending the lifetime of the optics themselves.

Nitrogen, normally supplied from bottles, cylinder packs or cryogenic storage tanks, can now be supplied on-site, meaning you are no longer dependent on traditional gas-supply sources.

A SMART ALTERNATIVE SOLUTION

With CLAIND nitrogen generators you **no longer need to worry about:**

- **reordering:** no more reliance on external suppliers
- **binding contracts:** your company has not to be exposed to unilateral contract “renewals”
- **safety:** your personnel need not to handle pressurised containers
- **monitoring on tank levels:** you will pay only for nitrogen you really need
- **running costs:** a generators means a fixed asset that adds value to your company

With the on-site generation **you also could reduce pollution problems**, associated with periodic deliveries of nitrogen.

LASER CUT & LASER GUIDE

Claind nitrogen generators

Choosing a Claind generator, means trusting the manufacturer who can guarantee:

ADVANCED TECHNOLOGY TAILORED TO HIGH PURITIES

The CLAIND solution for self-production of nitrogen makes use of **Pressure Swing Adsorption technology (PSA)**, which, through the use of specially selected molecular sieves (CMS), **makes it possible to obtain extremely pure nitrogen** (up to 99.9995%) **at very moderate cost.**

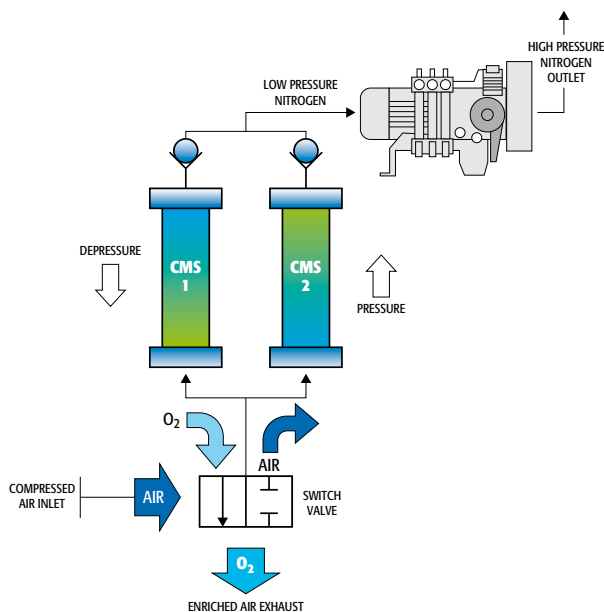

Claind has improved the PSA technology with the exclusive **internationally patented FAST PURITY™ system, which ensures:**

- the maximum purity of nitrogen available just a few minutes after start-up
- increased working life of the generator
- reduced mechanical stress
- higher efficiency
- lower consumption of air and electrical power and very high levels of purity obtainable
- more compact system



COMPLIANCE WITH THE TECHNICAL REQUIREMENTS OF THE WORLD'S TOP MANUFACTURERS OF LASER CUTTING MACHINES

The Claind R&D department has developed a range of nitrogen generators on the basis of specific nitrogen utilisation techniques issued by manufacturers of laser cutting machines

ADVANCED CONTROL SYSTEM

the LASER CUT and LASER GUIDE are equipped with an advanced control system, which makes possible to:

- control the maintenance of nitrogen purity and the required flow rates through time
- program machine operation in line with specific requirements
- generate process and consumption statistics
- verify signals faults and servicing required

A HIGHLY COMPACT LAYOUT

the small and extremely compact dimensions of Claind generators guarantee the smallest possible footprint

AN EFFECTIVE PRE- AND AFTER-SALES ASSISTANCE SERVICE

Before buying, Claind commercial consultants suggest the best sizing to meet customers needs, which guarantee the quality of cutting conditions, but also can avoid unnecessary cost. Regarding after sales, Claind technical assistance is available for:

- repair service and under guarantee maintenance
- maintenance agreements
- spare parts and consumables

TRANSPARENT COSTS

there are no surprises or hidden costs with a Claind generator: the only raw materials it uses are air and electricity, in quantities which depend on the output required.



LASER CUT

the solution for cutting assist gas

LASER CUT stands apart from other nitrogen generators because it incorporates a sophisticated system for the production of high purity nitrogen and a powerful compressor capable of reaching working pressures of up to 300 bar, guaranteeing:

- the correct nitrogen pressure and flow rate always available at the nozzle, even when cutting **thick material**
- the ability to supply **several cutting machines concurrently** with no risk of production downtime
- the ability to install the generation system **in any position** in the production department

The nitrogen produced is **free of oil and contamination** to ensure that the laser cutting machines will function perfectly and constantly.

The LASER CUT solution represents a systematic approach to laser cutting assist-gas requirements and consist mainly of:

An in-machine nitrogen generation and pressurization system

Storage of nitrogen at high pressure and cutting machine feed systems

Nitrogen generation process control software with a selection of operating programs that can be configured in line with cutting requirements



FEATURES

- **“controlled” high purity:** an on-board oxygen analyzer guarantees purity of the gas produced at any time
- **complete integrated system:** unlike other nitrogen generators, these units do not require bulky and unreliable external compressors
- **efficiency:** the system is extremely efficient, with lower power consumption than any other product on the market
- **compact size:** LASER CUT is the smallest high pressure nitrogen generator in its power class
- **tested with the leading manufacturers of laser cutting machines**
- in compliance with **EC directives (including PED)**

SPECIFICATIONS

- Nitrogen flow rate from 0 to 400 Nm³/h
- Pressure adjustable from 0 to 50 bar (available pressure up to 300 bar)
- From 160 Nm³ pressure cylinder rack storage systems
- Purity from 99.99 to 99.999%
- Production output: up to 23,800 Nm³/month

This unit can also be equipped with various optional customizations:

- **Remote connection option:** thanks to the presence of a PLC, the system can be constantly monitored and remotely accessed so that all monitoring data can be viewed on any PC in the company intranet
- **Night-time option:** allows system starting and stopping to be set at the required times, also from a remote PC, in order to allow savings in electricity consumption
- **Heating option:** for all applications in which operating temperature may fall below 5°C
- **Light gauge option:** special system configuration resulting in an increase of production capacity of around 20-30% without affecting power consumption
- **Low delivery pressure option:** the system is equipped with a second outlet connection in addition to the high pressure outlet. The additional outlet can be used to supply the laser beam guide, as prescribed by leading laser cutting machine manufacturers, for greater efficiency in the transmission of beam energy and reduced risk of contamination caused by any oil particles entering in to the compressed air

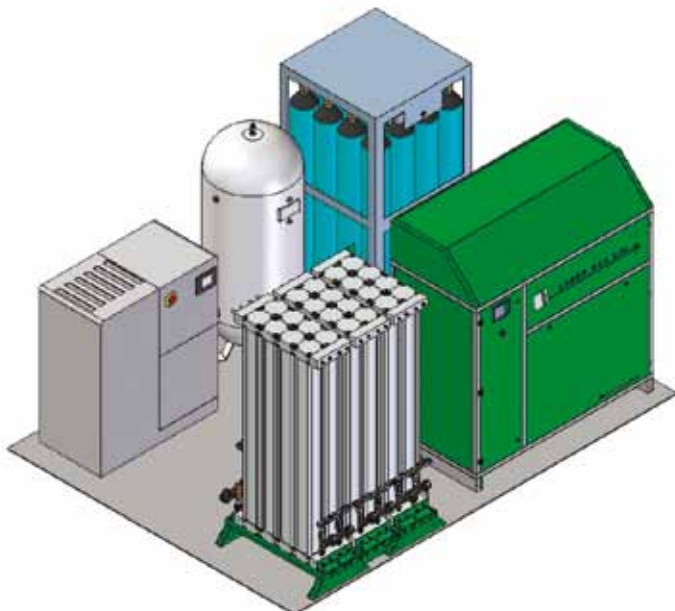

The LASER CUT line is composed of a series of models defined in accordance with the nitrogen flow rate and purity.

MODELS AVAILABLE

MODEL	AVERAGE NITROGEN PRODUCTION PER MONTH* Nm ³	CYLINDERS PACKS
LASER CUT 225-1	4.300	30
LASER CUT 225-2	8.600	60
LASER CUT 450-3	12.900	90
LASER CUT 450-4	16.000	110

* Nitrogen production at the pressure of 200 bar based on an average working cycle of 16 hours/day (6000 hours/year). The equivalent cylinder packs figures refer to 16 x 50 litres packs

** It's also available an intermediate model, the LASER CUT 450-2



LASER GUIDE

the solution for protection of the beam guide

Working hand-in-hand with its technological partners, Claind has developed a specific system to protect the laser optical path.

For some time now, many manufacturers have been selling **units that require significant supplies of inert gas** for pressurization of the beam guide.

Claind has therefore specifically created the LASER GUIDE system, which allows **high output of that mixture of guaranteed purity and an up to 80% reduction in maintenance requirements for cleaning of optical components.**

Successfully tested in combination with all commercially available laser optics, the LASER GUIDE makes it possible to **reduce the risk of the ingress of impurities** thereby significantly extending the lifetime of the optics.

Also machines developed with a compressed air beam guidance system can benefit from the use of LASER GUIDE, which offers greater efficiency in the transmission of laser beam energy and reduced risk of contamination by the oil particles that may be present in the compressed air supply.

This product can **function independently 24 hours/day** without stopping.

An oxygen analyzer installed as standard guarantees high quality of the gas output and emits an audible alarm signal to alert the operator in the event of anomalies.

Finally, the high efficiency of the carbon molecular sieves utilised by Claind and the **absence of maintenance requirements** make for a very appreciable reduction in the cost of gas compared to other alternative sources.

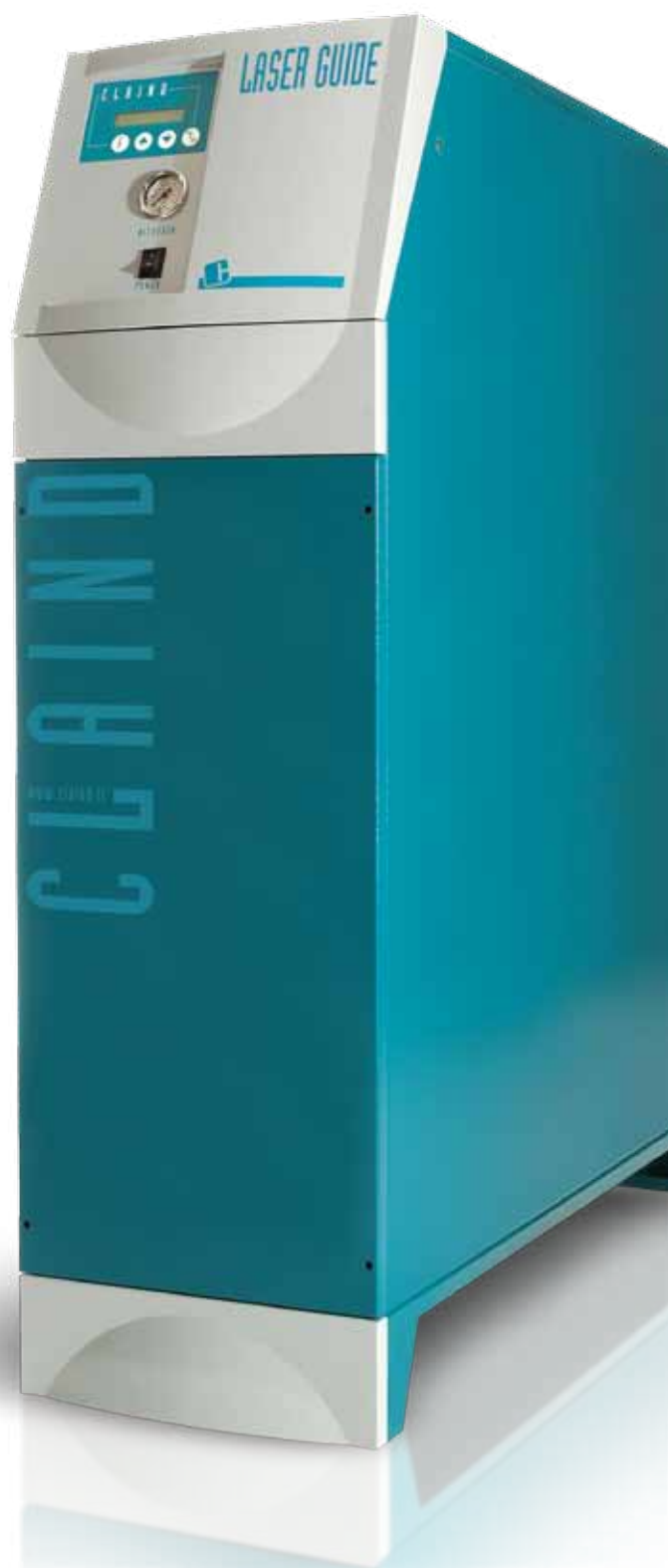

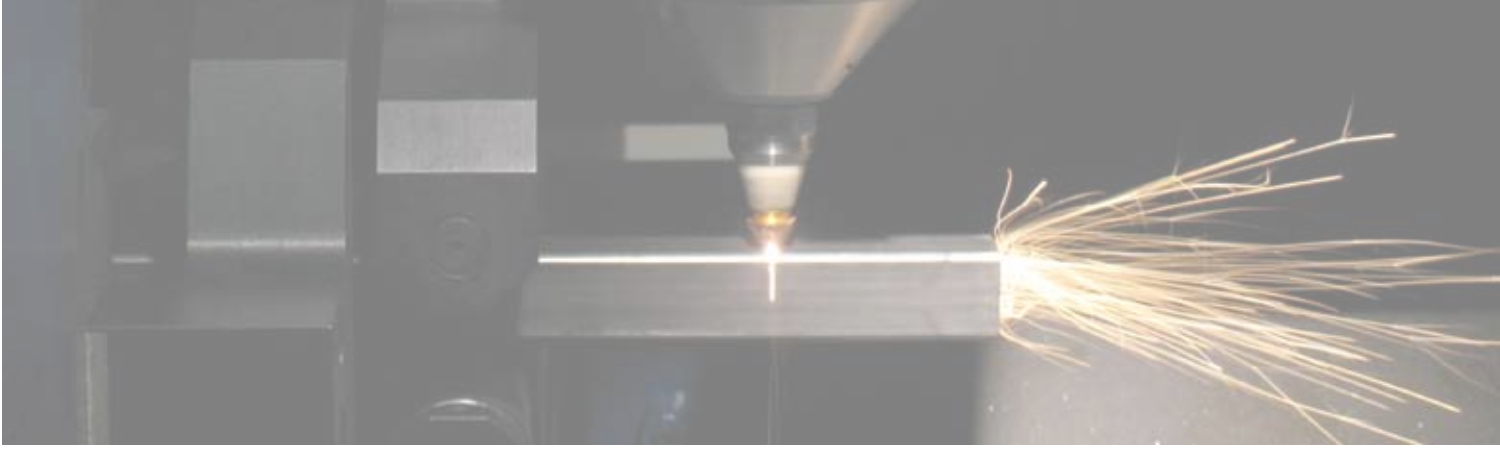

FEATURES

- Capacity: model 3 for 1-2 laser cutting machines; model 6 for 3-4 laser cutting machines
- Delivery pressure: from 4 to 6 bar
- **Pressure Swing Adsorption technology (PSA):** this technology, using CMS, allows to have an inert mixture of Nitrogen and Argon without phthalates, hydrocarbons and CO₂, as well as to provide an amount of oxygen and moisture completely suitable to optics and laser path.
- Microprocessor controller with alarm system interfaceable with centralized systems
- **“Fast Purity” patent** guarantees consistently high purity in all operating conditions
- The generator produces exclusively the quantity of gas required by the application and switches to stand-by mode when consumption is zero
- Each model is supplied as standard with a built-in oxygen analyzer
- Built-in pressure regulator
- Complies with EC directives (including PED)
- Designed in compliance with UL and ASME standards

TECHNICAL FEATURES

MODEL	N° of LASER BEAM served	CAPACITY (Nm ³ /h)
LASER GUIDE 3	1-2	7,5
LASER GUIDE 6	3-4	15





CLAI ND

Via Regina 24
22016 Lenno (CO)
Italy

Ph. +39 0344 56603

Fax +39 0344 56627

e-mail: info@claind.it

website: www.lasercutting.claind.it

